

Rem A

ADMINISTRATIVE DISCUSSION OF EFFICIENCY AND WATER CONSERVATION

WATER RESOURCES REVIEW COMMITTEE
SEPTEMBER 26, 2013

DISCUSSION

- × What is “Efficiency?”
- × Distinguish “Conservation” from “Efficiency”
- × Legal considerations

CONSERVATION

- ✘ In Colorado's system of water administration, Conservation should be distinguished from the term Efficiency. In agriculture and other water uses, Efficiency has a specific meaning:

Efficiency is the ratio of the amount of water consumed by a specific beneficial use to the amount of water that must be diverted to achieve the beneficial use.

EXPLANATION OF EFFICIENCY

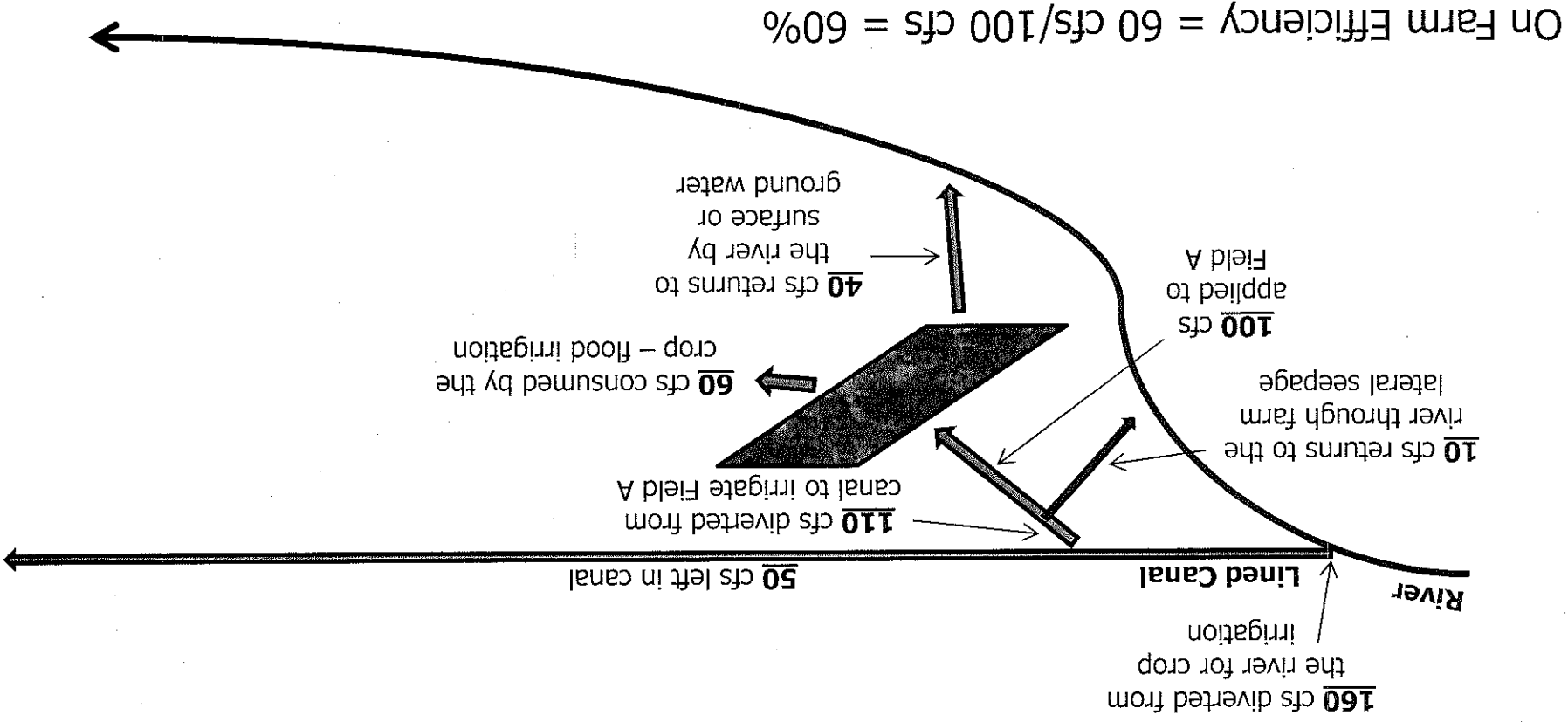

On Farm Efficiency = $60 \text{ cfs} / 100 \text{ cfs} = 60\%$

Note: Out of the 160 cfs diverted, 50 cfs is available to be diverted by other users on the lined canal.

EFFICIENCY

- ✘ Therefore, in Colorado's system of water administration, increased efficiency, is a change in the means of diversion or application of water to a specific beneficial use.
- ✘ Three components potentially affected: diversions, consumption, and return flows.

Even if the specific beneficial use does not consume more water, changes to efficiency can affect the amount of water consumed by others in the basin. We'll discuss that more.

EFFICIENCY

- × Example of Efficiency in Agricultural Irrigation:
 - + Modifying the method of diversion or application of the water
 - × Lining the ditch
 - × Switching from flood to sprinkler irrigation
- × Important points:
 - + Efficiency changes affect return flows
 - × This effect may influence water availability upstream or downstream due to a change in the timing, location, and amount of the historical return flow pattern
 - × The effect may have interstate compact implications
 - + Water not diverted due to efficiency improvements becomes available to the water users of the state to be beneficially used in accordance with the priority system
 - × Therefore, it may be consumed by a different water user than before the efficiency improvement

EFFICIENCY BEFORE IMPROVEMENTS

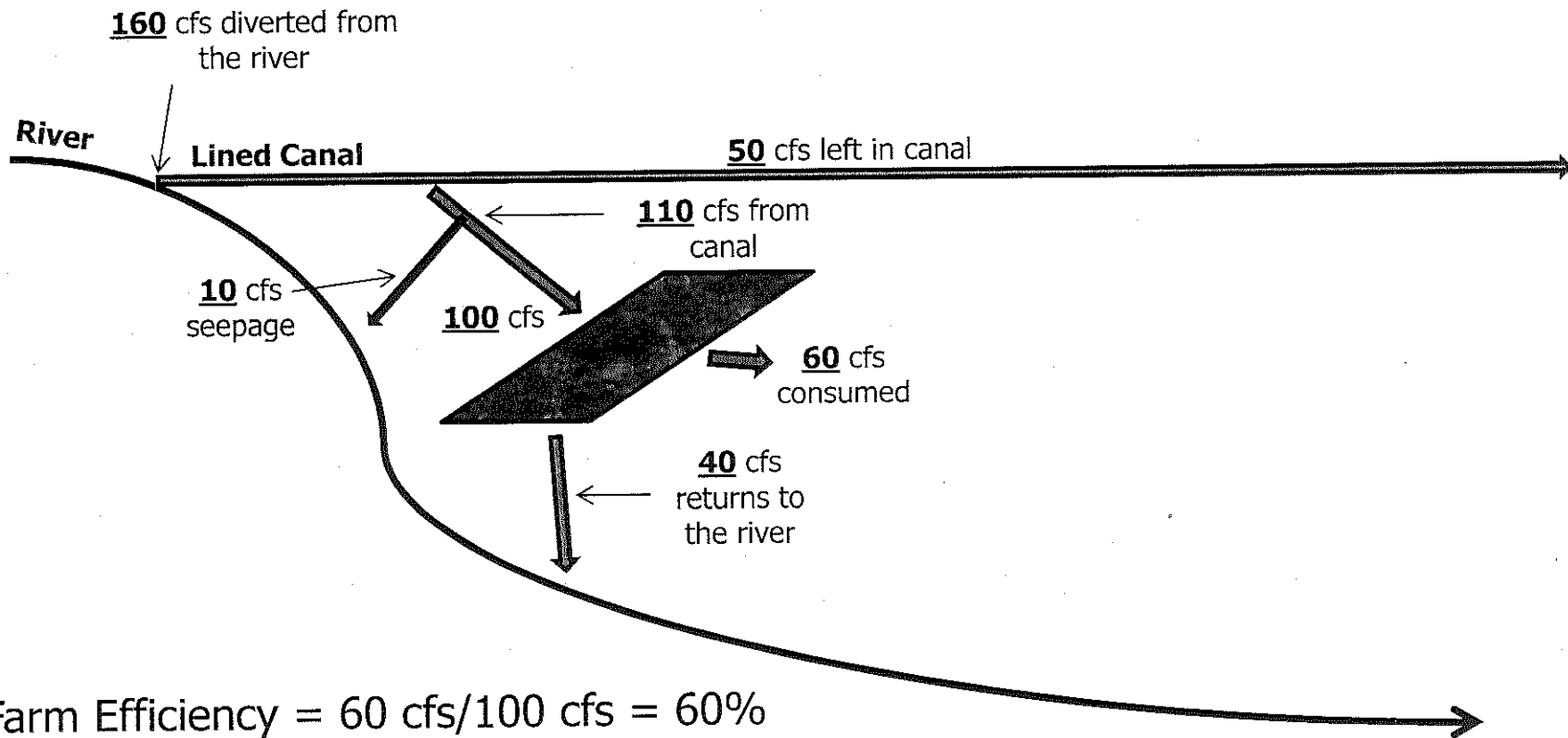

EFFICIENCY BEFORE IMPROVEMENTS

Now consider Field B...

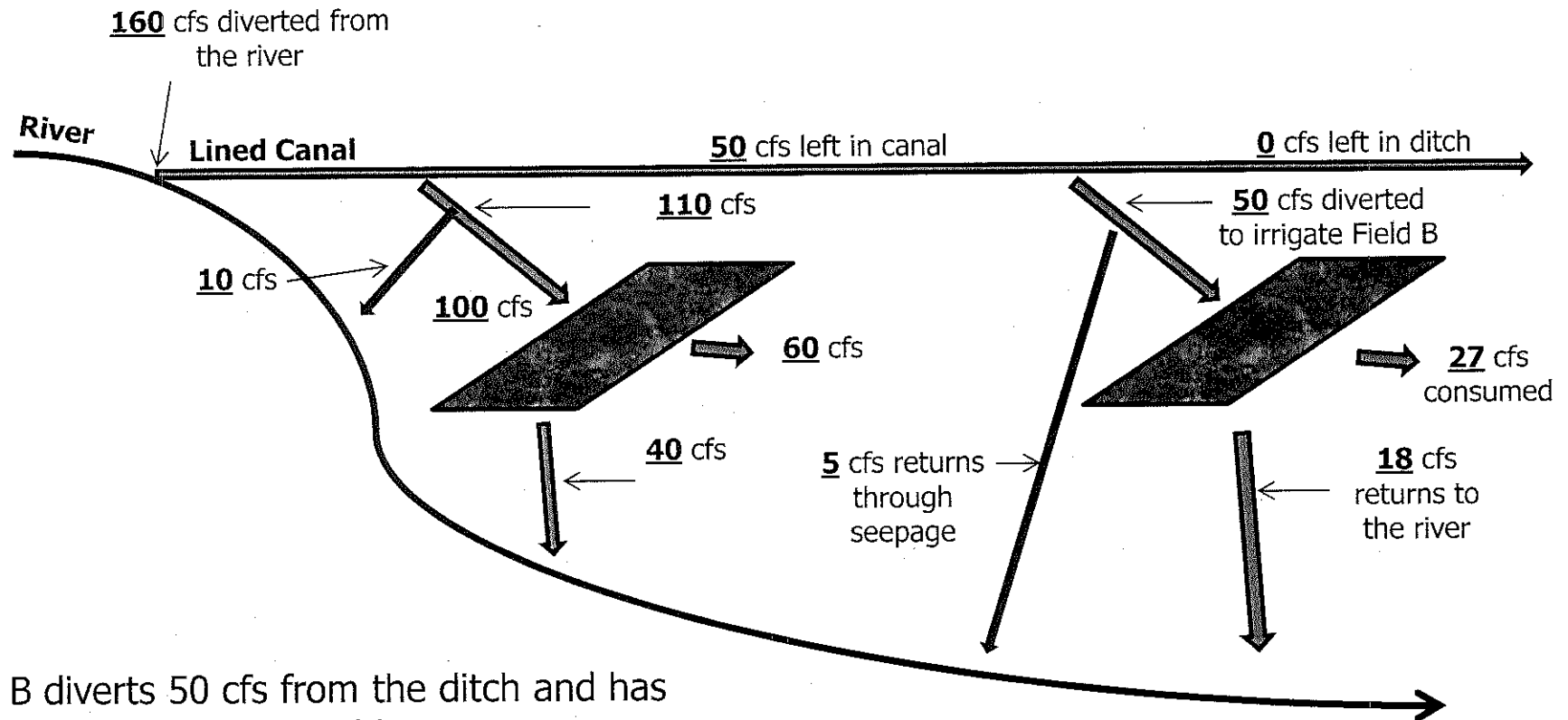

Field B diverts 50 cfs from the ditch and has the same efficiency as Field A.

However, Ditch B actually has the right to and needs 110 cfs too, but there is only 50 cfs available. The canal system is "water short."

EFFICIENCY AFTER IMPROVEMENTS

Field A switches from flood to sprinkler.
Efficiency goes from 60% to 80%

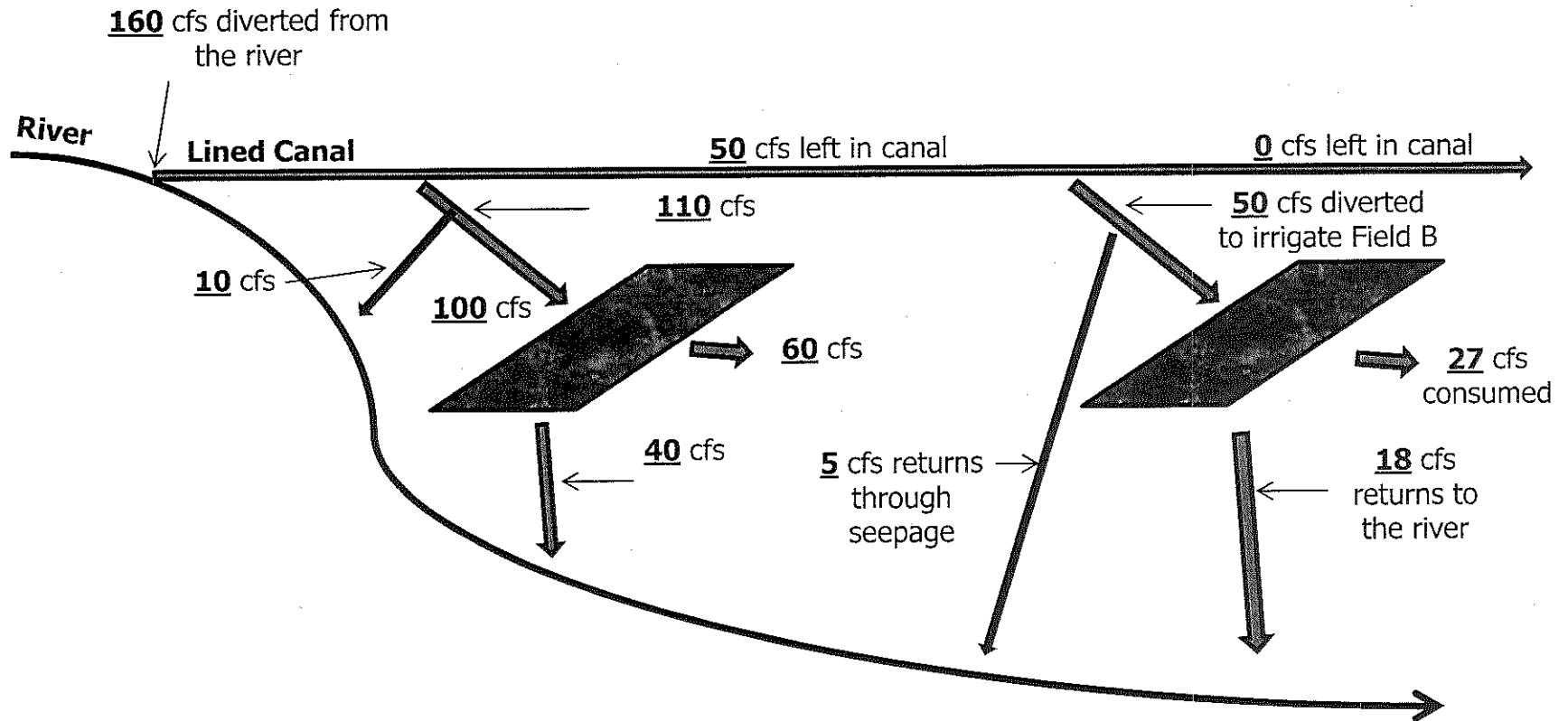

EFFICIENCY AFTER IMPROVEMENTS

Field A switches from flood to sprinkler.
Efficiency goes from 60% to 80%

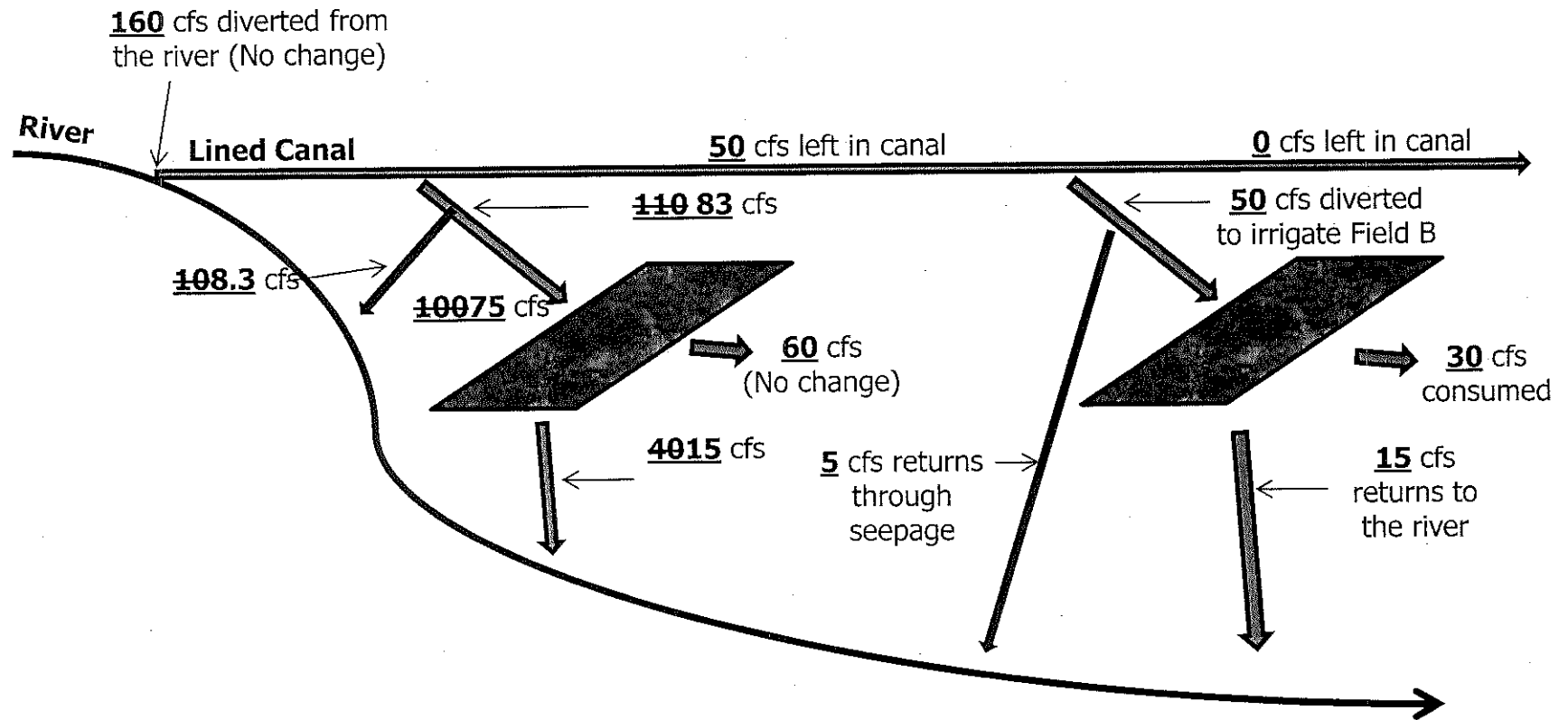

EFFICIENCY AFTER IMPROVEMENTS

Field A switches from flood to sprinkler.
Efficiency goes from 60% to 80%

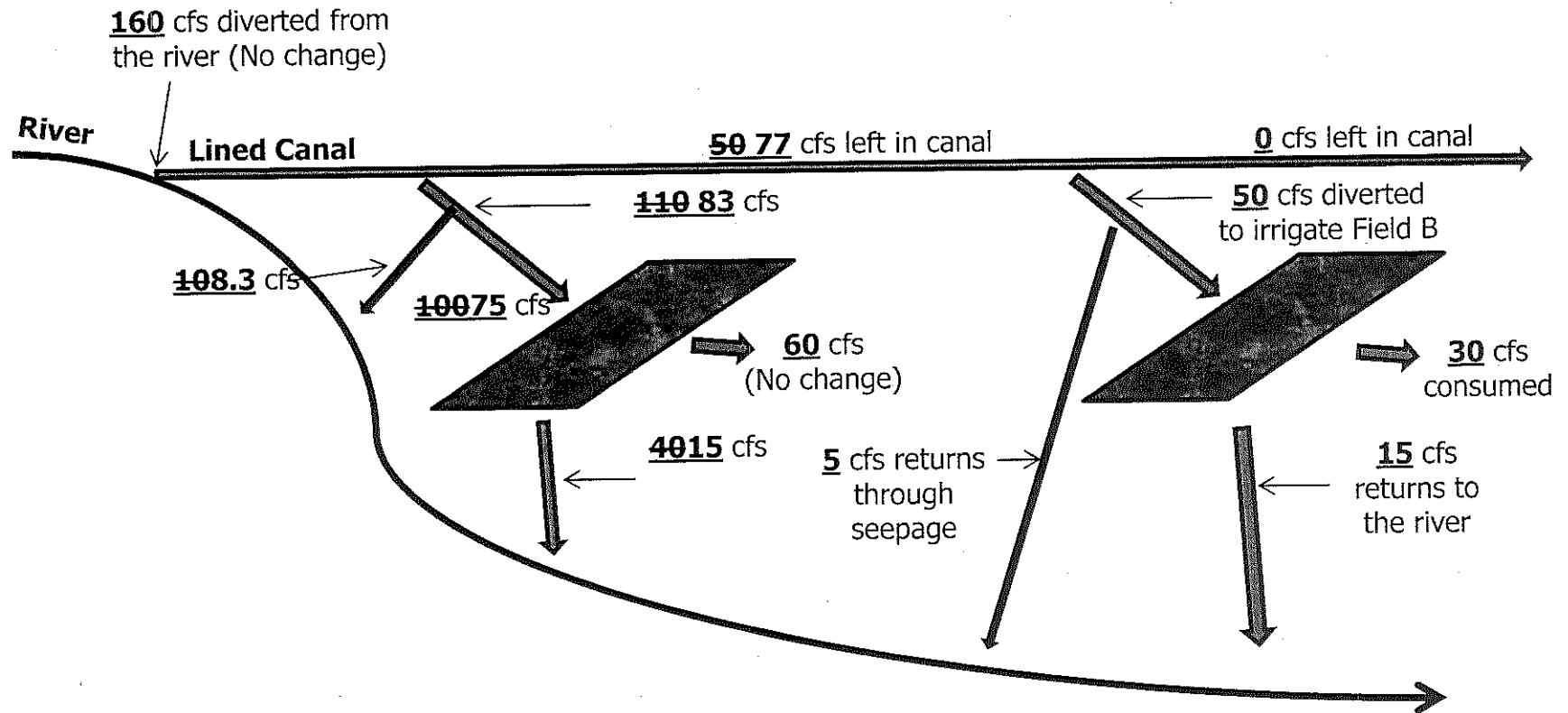

EFFICIENCY AFTER IMPROVEMENTS

Field A switches from flood to sprinkler.
Efficiency goes from 60% to 80%

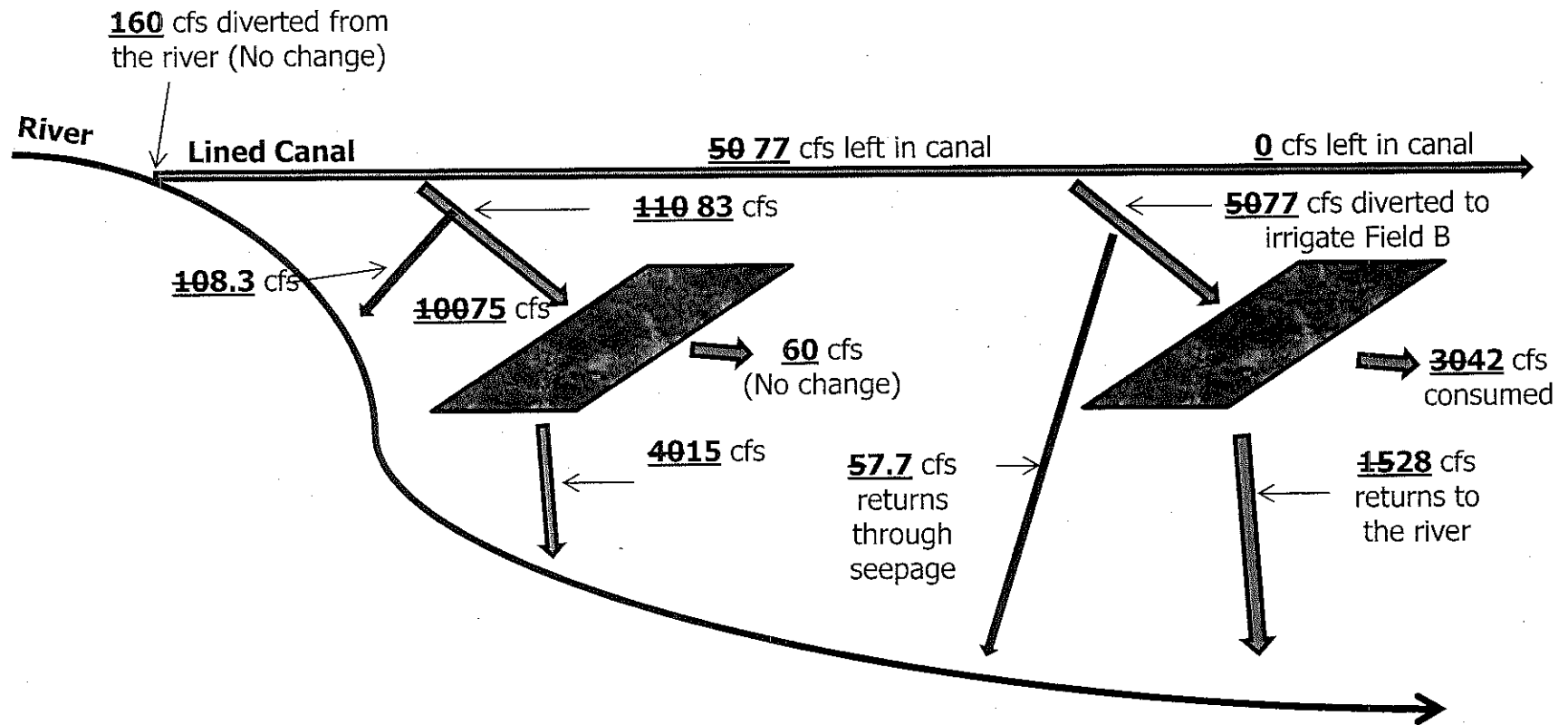

EFFICIENCY AFTER IMPROVEMENTS

What is the effect?

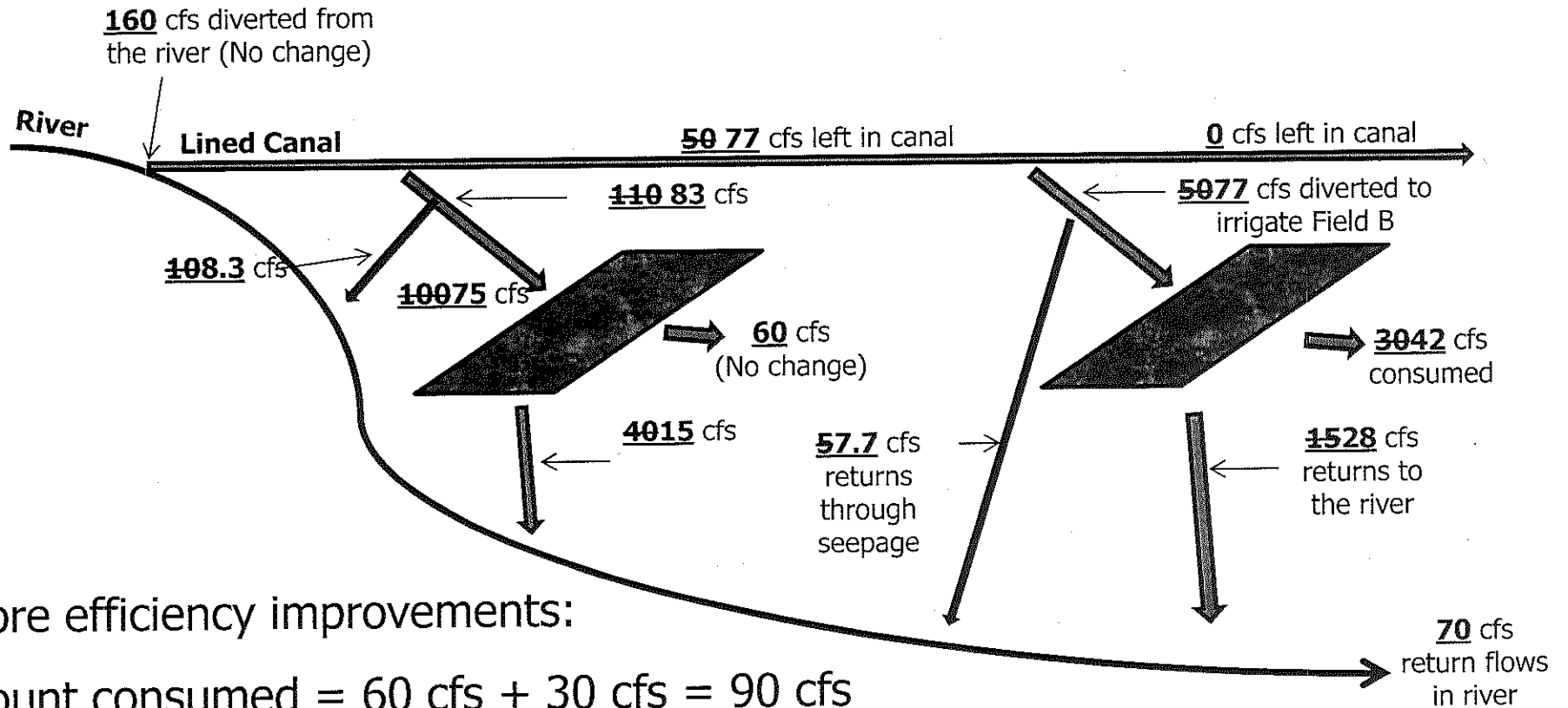

Before efficiency improvements:

Amount consumed = 60 cfs + 30 cfs = 90 cfs

Amount returned = 10 cfs + 40 cfs + 5 cfs + 15 cfs = 70 cfs

EFFICIENCY AFTER IMPROVEMENTS

What is the effect?

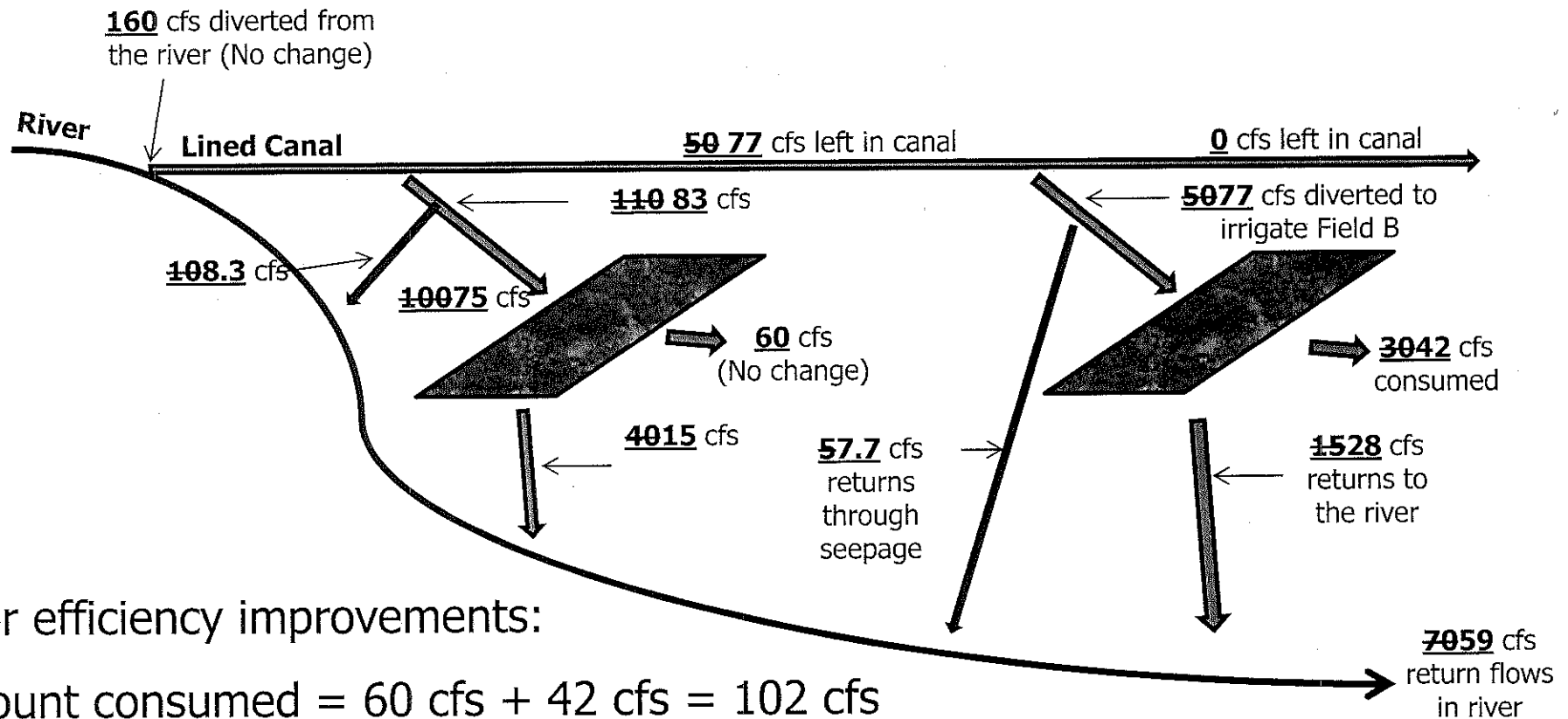

After efficiency improvements:

Amount consumed = 60 cfs + 42 cfs = 102 cfs

Amount returned = 8.3 cfs + 15 cfs + 7.7 cfs + 28 cfs = 59 cfs

EFFICIENCY

- × Example of Efficiency in Agricultural Irrigation:
 - + Modifying the method of diversion or application of the water
 - × Lining the ditch
 - × Switching from flood to sprinkler irrigation
- × Important points:
 - + Efficiency changes affect return flows
 - × This effect may influence water availability upstream or downstream due to a change in the timing, location, and amount of the historical return flow pattern
 - × The effect may have interstate compact implications
 - + Water not diverted due to efficiency improvements becomes available to the water users of the state to be beneficially used in accordance with the priority system
 - × Therefore, it may be consumed by a different water user than before the efficiency improvement

EFFICIENCY

- × Example of Efficiency in Agricultural Irrigation:
 - + Modifying the method of diversion or application of the water
 - × Lining the ditch
 - × Switching from flood to sprinkler irrigation
- × Important points:
 - + Efficiency changes affect return flows
 - × This effect may influence water availability upstream or downstream due to a change in the timing, location, and amount of the historical return flow pattern
 - × The effect may have interstate compact implications
 - + Water not diverted due to efficiency improvements becomes available to the water users of the state to be beneficially used in accordance with the priority system
 - × Therefore, it may be consumed by a different water user than before the efficiency improvement

EFFICIENCY

- × Example of Efficiency in Agricultural Irrigation:
 - + Modifying the method of diversion or application of the water
 - × Lining the ditch
 - × Switching from flood to sprinkler irrigation
- × Important points:
 - + Efficiency changes affect return flows
 - × This effect may influence water availability upstream or downstream due to a change in the timing, location, and amount of the historical return flow pattern
 - × The effect may have interstate compact implications
 - + Water not diverted due to efficiency improvements becomes available to the water users of the state to be beneficially used in accordance with the priority system
 - × Therefore, it may be consumed by a different water user than before the efficiency improvement

EFFICIENCY - LEGAL CONSIDERATIONS

× Efficiency

+ Arkansas River Compact

- × Irrigation Improvement Rules in the Arkansas River Basin
- × Other parts of state do not have this requirement

- + Measure of a water right is its historical consumptive use.
- + If a ditch system is “water long,” efficiency savings cannot be transferred to another use
- + In an over-appropriated system, water saved through efficiency improvements will likely be consumed by another water user, or even by the same user themselves

SIMPLIFIED SCENARIO

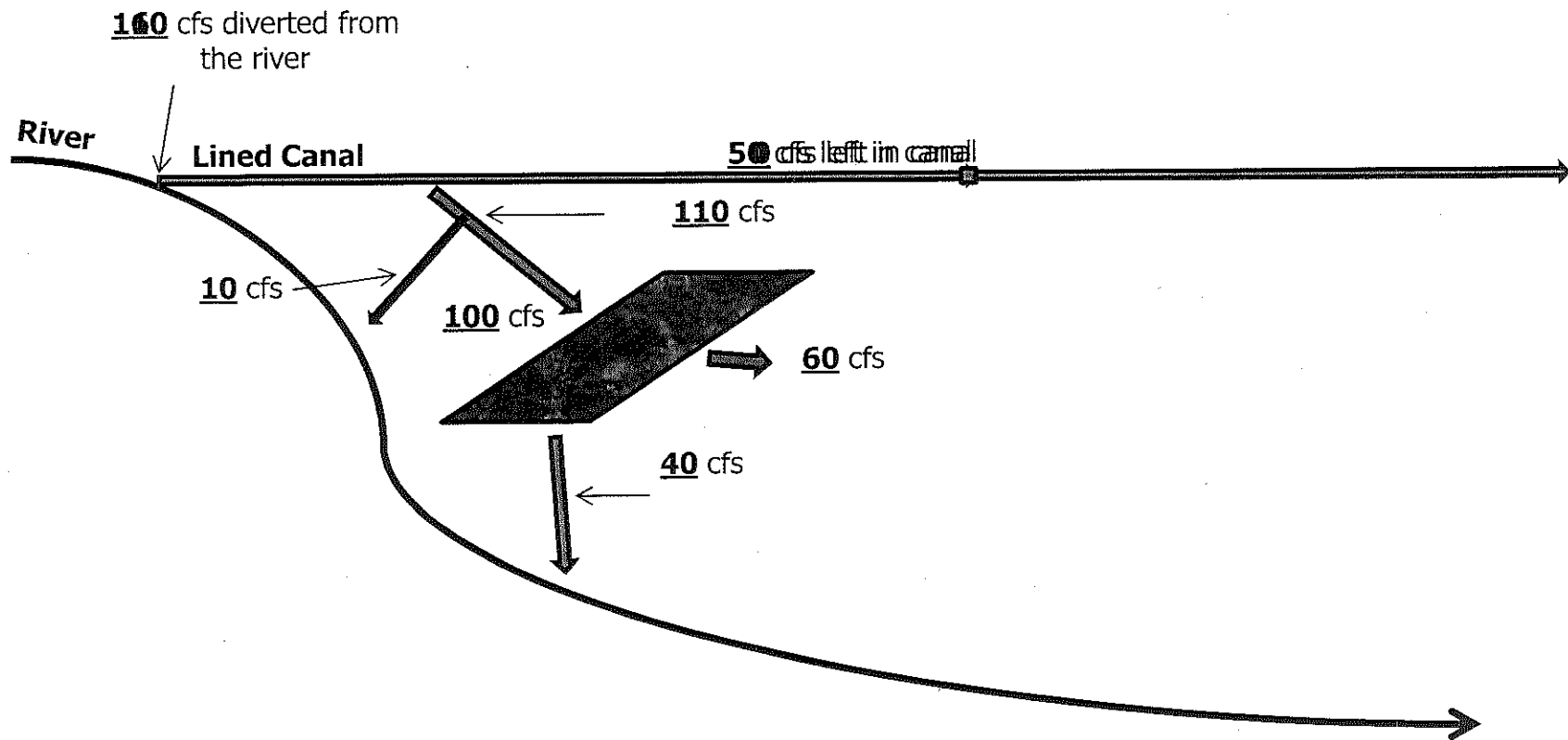

SIMPLIFIED SCENARIO

Field switches from flood to sprinkler.
Efficiency goes from 60% to 80%

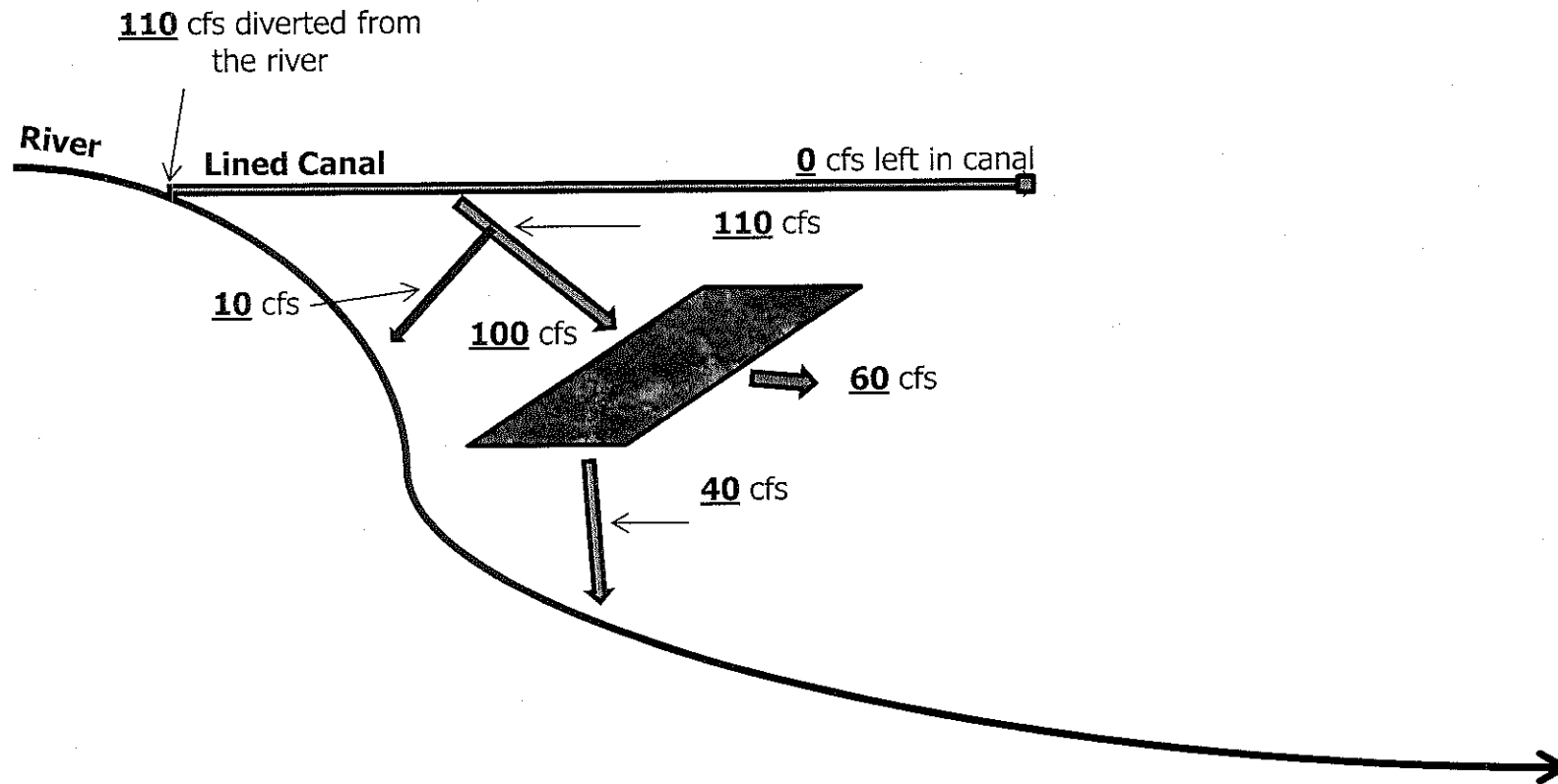

SIMPLIFIED SCENARIO

Field switches from flood to sprinkler.
Efficiency goes from 60% to 80%

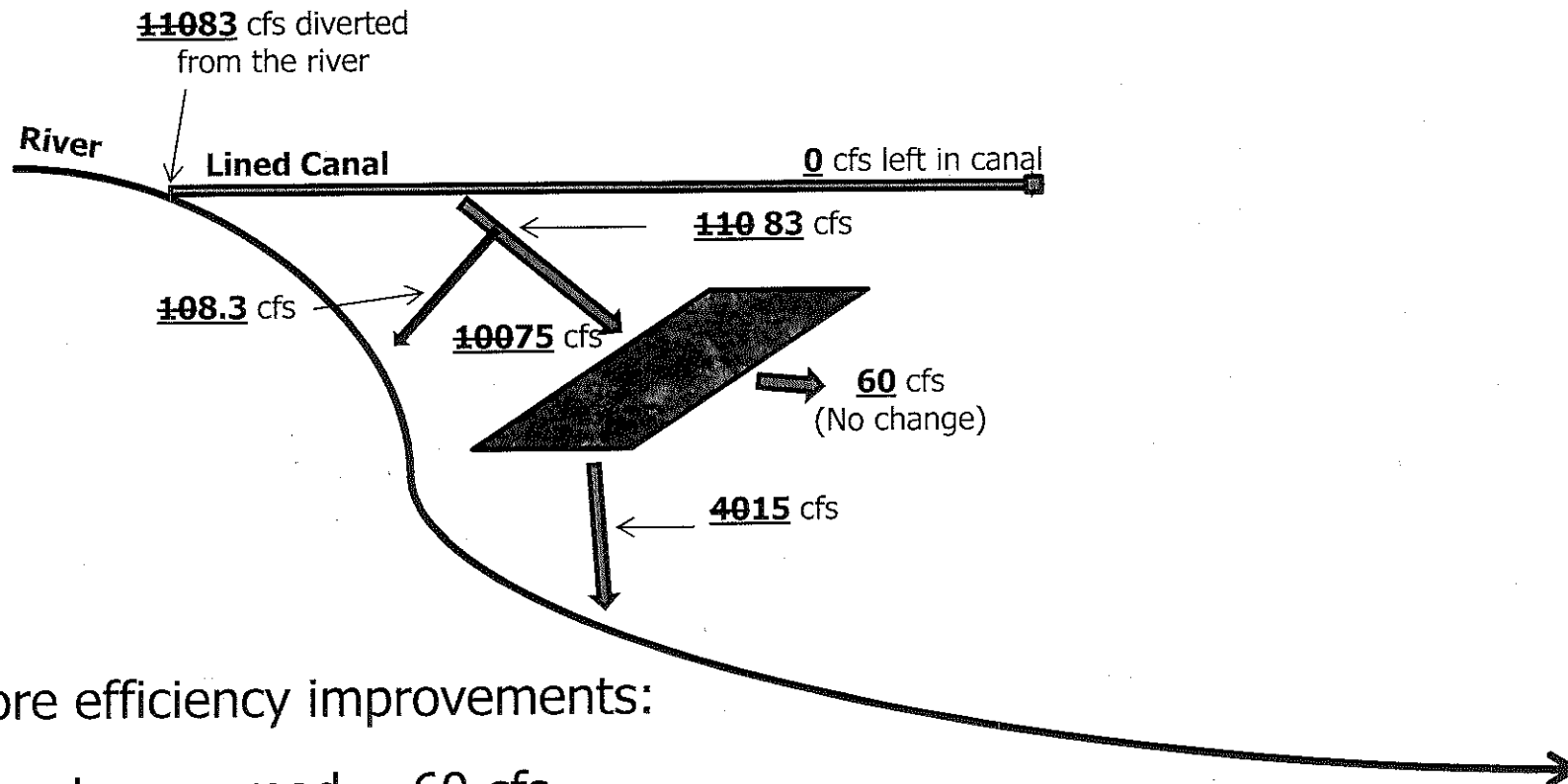

Before efficiency improvements:

Amount consumed = 60 cfs

Amount returned = 10 cfs + 40 cfs = 50 cfs

SIMPLIFIED SCENARIO

Field switches from flood to sprinkler.
Efficiency goes from 60% to 80%

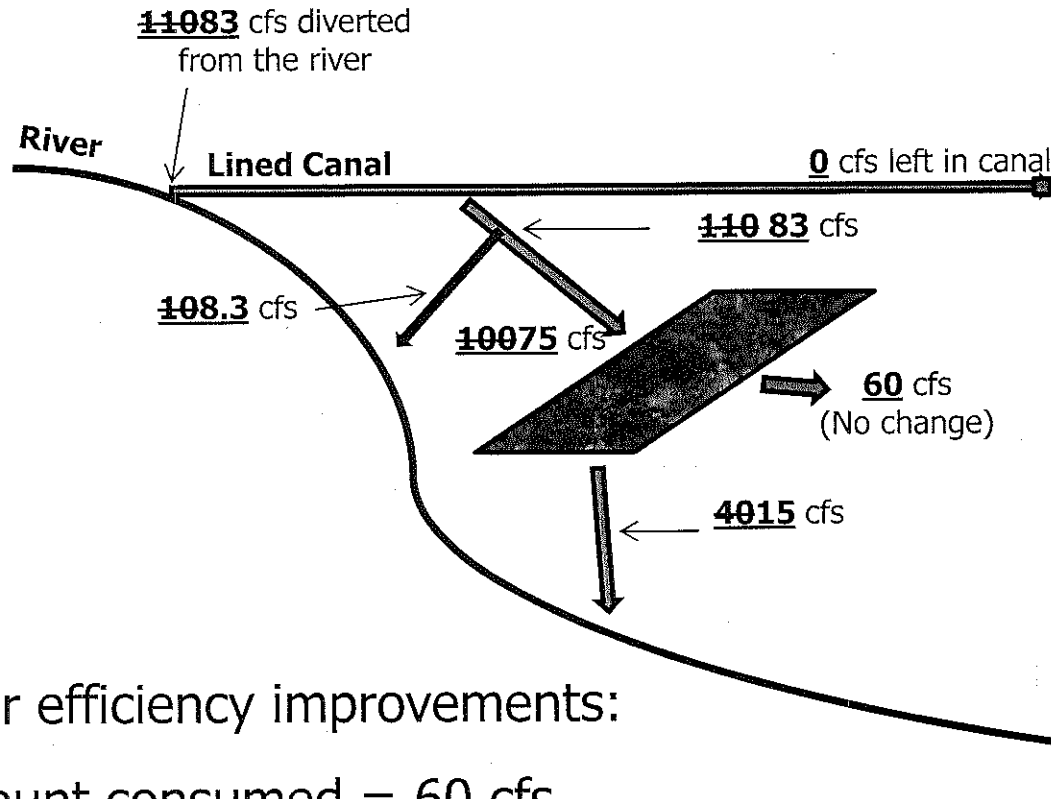

Return flows decrease by 27 cfs, but an extra 27 cfs was left in the river.

Where is the impact?

Timing

Before the change, return flows gradually accrued to the river over months, or years

After efficiency improvements:

Amount consumed = 60 cfs

Amount returned = 8.3 cfs + 15 cfs = 23 cfs

After the change, return flows are immediately available in the river for appropriation,

SIMPLIFIED SCENARIO

- × So even in our simplified scenario...
 - + In some cases, even if there is no increased consumption and
 - + Even if the volume of return flows is the same
 - × Return flows before efficiency changes occurred at the river during a certain time, available to a certain set of water rights,
 - × Return flows after efficiency occur at the river immediately, possibly picked up by different water rights

IN CONTRAST...

Conservation

CONSERVATION

- ✘ Distinguish Conservation from Efficiency
- ✘ In Colorado's system of water administration, Conservation is the effort to modify the use of water, with the primary objective and result being a reduction in the amount of water consumed or taken out of the hydrologic cycle.

CONSERVATION

× Example of Conservation in Agricultural Irrigation:

- + Taking land out of production
 - × Remove end guns
 - × Fallow a field
 - × Irrigating a less consumptive crop

× Important points:

- + Taking land out of production could lead to abandonment if not done according to a formally recognized program – see 37-92-103(2)
- + Irrigating a less consumptive crop on the same land may result in a reduction of water being consumed but would still be administratively regarded as a full exercise of the water right
- + Water saved through conservation will likely be consumed by another water user in an over-appropriated system

CONSERVATION - LEGAL CONSIDERATIONS

× Conservation

- + 37-92-103(2), Intent to abandon shall not result from...
- + 37-92-305(3)(c), In historical use analyses, the judge shall not consider decreases in use that result from...(SB13-019)
- + 37-90-108(5)(b), “Conservation” is not grounds to reduce the water right of a final permit (SB13-075)